

Description

Single pole press-to-reset thermal circuit breaker with extremely fast overload switching performance (R-type TO CBE to EN 60934). Single hole threadneck, PCB or integral mounting with a choice of designs. Miniaturised construction minimises PCB real estate required. Type 1410-L2 and 1410-G1 versions feature changeover contacts suitable for providing status output signals. Largely temperature-insensitive.

Typical applications

Motors, transformers, solenoids, PCBs, hand-held machines, appliances, instrumentation.

Ordering information

Type No.	1410	single pole circuit breaker
Mounting		
L2		PCB mounting or integral mounting 10.15 x 7.62
G1		threadneck panel mounting or PCB mounting
Number of poles		
1		1-pole, thermally protected
Hardware		
0		without
1		with hexnut and knurled nut (only 1410-G), bulk shipped with 5 pcs plus
Terminal design		
L2		solder pins 1x0.8 silver-plated
P2		blade terminals DIN 46244-A2.8-0.8 silver-plated (only -G)
Characteristic curve		
F1		fast acting
Actuator, type and colour		
S01		reset button, black (1410-G)
S02		reset slide, white (1410-L2)
Current ratings		
		0.63...10 A
1410 - L2 1 0 - L2 F1 - S 02 - 0.8 A ordering example		

Preferred types

Preferred types	Standard current ratings (A)									
	0.63	1	1.5	2	2.25	3.15	4	6.3	8	10
1410-G110-L2F1-S01-	x	x	x	x	x	x	x	x	x	x
1410-G111-P2F1-S01-	x	x	x	x	x	x	x	x	x	x
1410-L210-L2F1-S02-	x	x	x	x	x	x	x	x	x	x

Standard current ratings and typical internal resistance values

Current rating (A)	Internal resistance (Ω)	Current rating (A)	Internal resistance (Ω)
0.63	1.8	4	< 0.1
0.8	1.7	4.5	< 0.1
1	1.3	5	< 0.1
1.5	< 1	6.3	< 0.1
2	< 1	8	< 0.1
2.25	< 0.15	10	< 0.1
3.15	< 0.12		

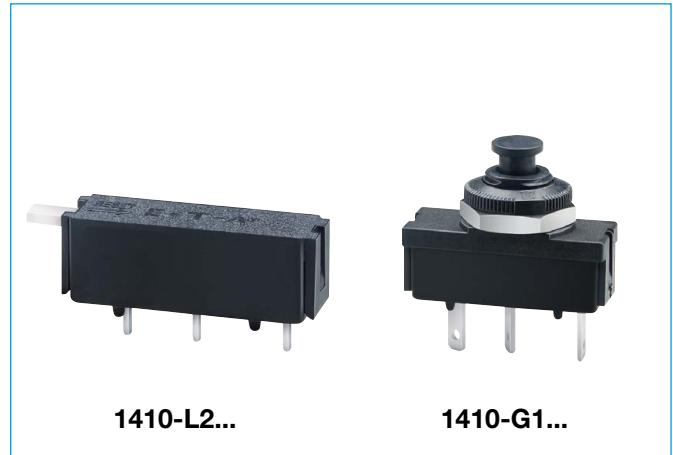

Technical data

For further details please see chapter: Technical Information			
Voltage rating	AC 240 V; DC 28 V (UL: AC 250 V; DC 50 V)		
Current rating range 1-2	0.63...10 A		
Auxiliary circuit 1-3	0.2 x I _N max. 1 A, AC 250 V		
Typical life	AC 240 V: 0.63...2.25 A 500 break operations at 2 x I _N , inductive 2.5...10 A 500 break operations at 2 x I _N , resistive DC 50 V: 0.63...2.25 A 500 break operations at 2 x I _N , inductive DC 28 V: 2.5...10 A 500 break operations at 2 x I _N , inductive		
Ambient temperature	-20...+70 °C (-4...+158 °F)		
Insulation co-ordination (IEC 60664 and 60664 A)	rated impulse withstand voltage 2.5 kV	pollution degree 2	reinforced insulation in operating area
Dielectric strength (IEC 60664 and 60664A) operating area	test voltage AC 1,500 V		
Insulation resistance	> 100 MΩ (DC 500 V)		
Interrupting capacity I _{cn} (o-o-o)	0.63...2 A 2.5...8 A 10 A 3.15...10 A	12 x I _N 8 x I _N , AC max. 50 A 6 x I _N , AC 10 x I _N , DC	
Interrupting capacity (UL 1077)	0.63...10 A 0.63...10 A	2,000 A 200 A	AC 250 V DC 50 V
Degree of protection (IEC 60529/DIN 40050)	operating area IP40 terminal area IP00		
Vibration	8 g (57-500 Hz) ± 0.61 mm (10-57 Hz), to IEC 60068-2-6, test Fc, 10 frequency cycles/axis		
Shock	20 g (11 ms) to IEC 60068-2-27, test Ea		
Corrosion	48 hours at 5 % salt mist, to IEC 60068-2-11, test Ka		
Humidity	96 hours at 95 % RH to IEC 60068-2-78, test Cab		
Mass	approx. 5 g		

Approvals

Authority	Standard	Rated voltage	Current ratings
VDE	IEC/EN 60934	AC 240 V DC 50 V DC 28 V	0.63 A...10 A 0.63 A...2.25 A 2.5 A...10 A
UL	UL 1077	AC 250 V DC 50 V	0.63 A...10 A 0.63 A...10 A
CSA	C22.2 No 235	AC 250 V DC 50 V	0.63 A...10 A 0.63 A...10 A

Dimensions

1410-L210-L2F1-S02

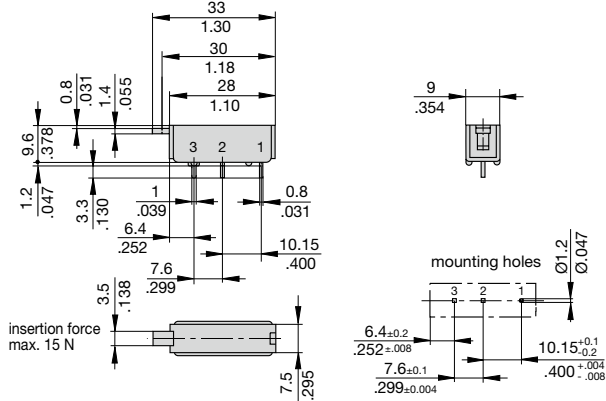

1410-G111-P2F1-S01

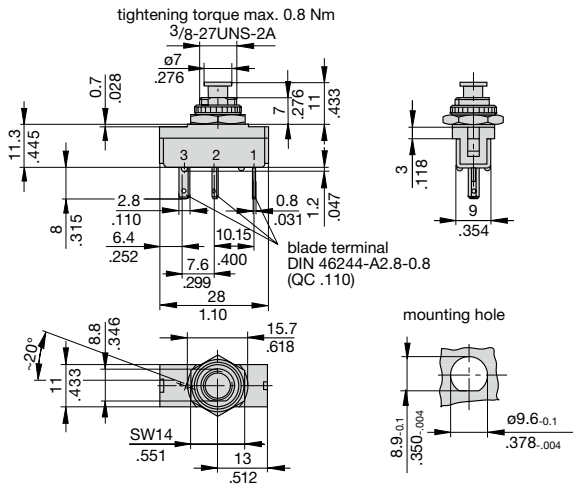

1410-G110-P2F1-S01

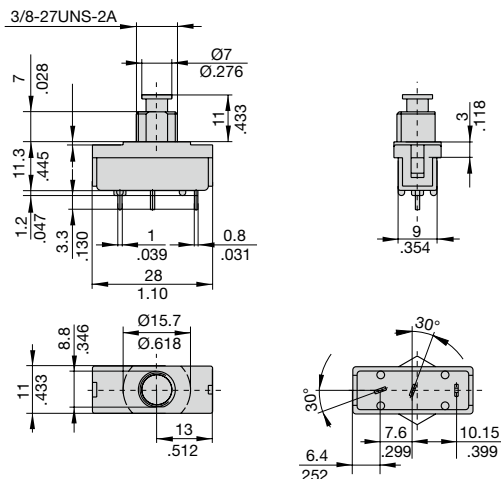

Internal connection diagram

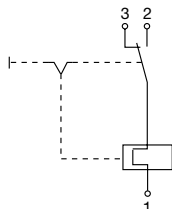

Typical time/current characteristics at +23 °C/+73.4 °F

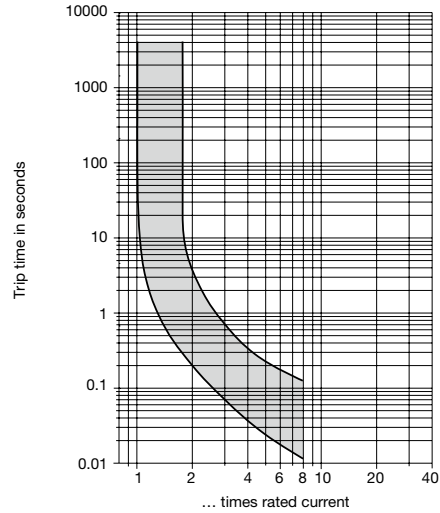

Installation drawings

1410-L2...

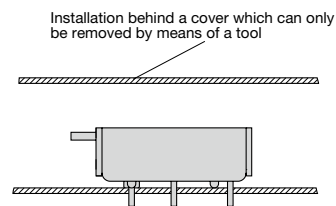

1410-G...

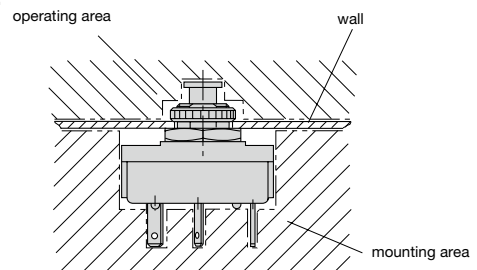

This is a metric design and millimeter dimensions take precedence ($\frac{\text{mm}}{\text{inch}}$)

Accessory

Knurled nut 3/8" plastic
Y 307 117 02

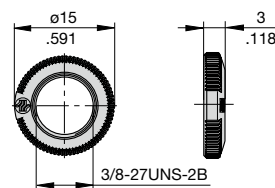

Hex nut 3/8" nickel-plated brass
Y 300 192 01

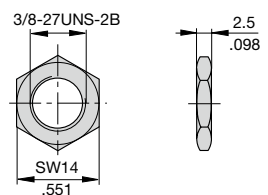

All dimensions without tolerances are for reference only. In the interest of improved design, performance and cost effectiveness the right to make changes in these specifications without notice is reserved. Product markings may not be exactly as the ordering codes. Errors and omissions excepted.

Mouser Electronics

Authorized Distributor

Click to View Pricing, Inventory, Delivery & Lifecycle Information:

E-T-A Circuit Breakers:

[1410-L210-L2F1-S02-2A](#) [1410-G111-L2F1-S01-3.15A](#) [1410-G111-P2F1-S01-6.3A](#) [1410-G110-L2F1-S01-2A](#) [1410-L210-L2F1-S02-3.15A](#) [1410-G110-L2F1-S01-4A](#) [1410-L210-L2F1-S02-6.3A](#) [1410-G111-P2F1-S01-1.5A](#) [1410-G110-L2F1-S01-0.8A](#) [1410-G110-L2F1-S01-3.15A](#) [1410-G111-L2F1-S01-10A](#) [1410-G110-P2F1-S01-2.5A](#) [1410-G110-L2F1-S01-1A](#) [1410-G110-P2F1-S01-10A](#) [1410-G110-L2F1-S01-0.63A](#) [1410-G111-P2F1-S01-1A](#) [1410-G110-P2F1-S01-1.8A](#) [1410-G110-L2F1-S01-1.5A](#) [1410-G111-P2F1-S01-3.15A](#) [1410-G110-P2F1-S01-7A](#) [1410-G110-P2F1-S01-1A](#) [1410-G111-L2F1-S01-6.3A](#) [1410-G111-P2F1-S01-8A](#) [1410-G111-L2F1-S01-2A](#) [1410-G110-P2F1-S01-1.5A](#) [1410-G111-P2F1-S01-5A](#) [1410-G110-P2F1-S01-5A](#) [1410-G111-L2F1-S01-5A](#) [1410-G111-L2F1-S01-4A](#) [1410-G111-L2F1-S01-1A](#) [1410-L210-L2F1-S02-5A](#) [1410-G110-P2F1-S01-4.5A](#) [1410-L210-L2F1-S02-4A](#) [1410-G110-L2F1-S01-10A](#) [1410-G110-P2F1-S01-3.15A](#) [1410-G111-P2F1-S01-10A](#) [1410-G110-P2F1-S01-2A](#) [1410-G110-L2F1-S01-2.5A](#) [1410-G111-L2F1-S01-2.5A](#) [1410-G110-P2F1-S01-8A](#) [1410-G111-L2F1-S01-0.63A](#) [1410-G110-P2F1-S01-6.3A](#) [1410-G110-P2F1-S01-4A](#) [1410-L210-L2F1-S02-8A](#) [1410-G111-P2F1-S01-1.8A](#) [1410-G111-P2F1-S01-0.63A](#) [1410-G111-L2F1-S01-1.5A](#) [1410-G110-L2F1-S01-6.3A](#) [1410-G110-L2F1-S01-8A](#) [1410-G110-L2F1-S01-5A](#) [1410-G111-P2F1-S01-2A](#) [1410-G111-P2F1-S01-2.5A](#) [1410-G111-P2F1-S01-4.5A](#) [1410-G111-P2F1-S01-4A](#) [1410-L210-L2F1-S02-4.5A](#) [1410-G110-P2F1-S01-0.63A](#) [1410-L210-L2F1-S02-1A](#) [1410-L210-L2F1-S02-2.5A](#) [1410-L210-L2F1-S02-1.8A](#) [1410-G114-P3F1-S01-2A](#) [1410-G114-P3F1-S01-0.63A](#) [1410-G114-P3F1-S01-1.5A](#) [1410-G111-P2F1-S01-385803-8A](#) [1410-L210-L2F1-S02-10A](#) [1410-L210-L2F1-S02-0.63A](#) [1410-L210-L2F1-S01-1.25A](#) [1410-L210-L2F1-S02-1.25A](#) [1410-G111-P2F1-B04-1A](#) [1410-L210-L2F1-S02-1.5A](#) [1410-L210-L2F1-S02-0.8A](#) [1410-G110-P2F1-B04-1A](#) [1410-G114-P3F1-S01-5A](#) [1410-F110-P1F1-W19QE3-4A](#)